

R&I
MANUFACTURING CO.

DURA-THRUST
VERTICAL - LIGHT DUTY HORIZONTAL
LINEAR THRUSTER

ET-3

DIMENSIONAL DRAWING

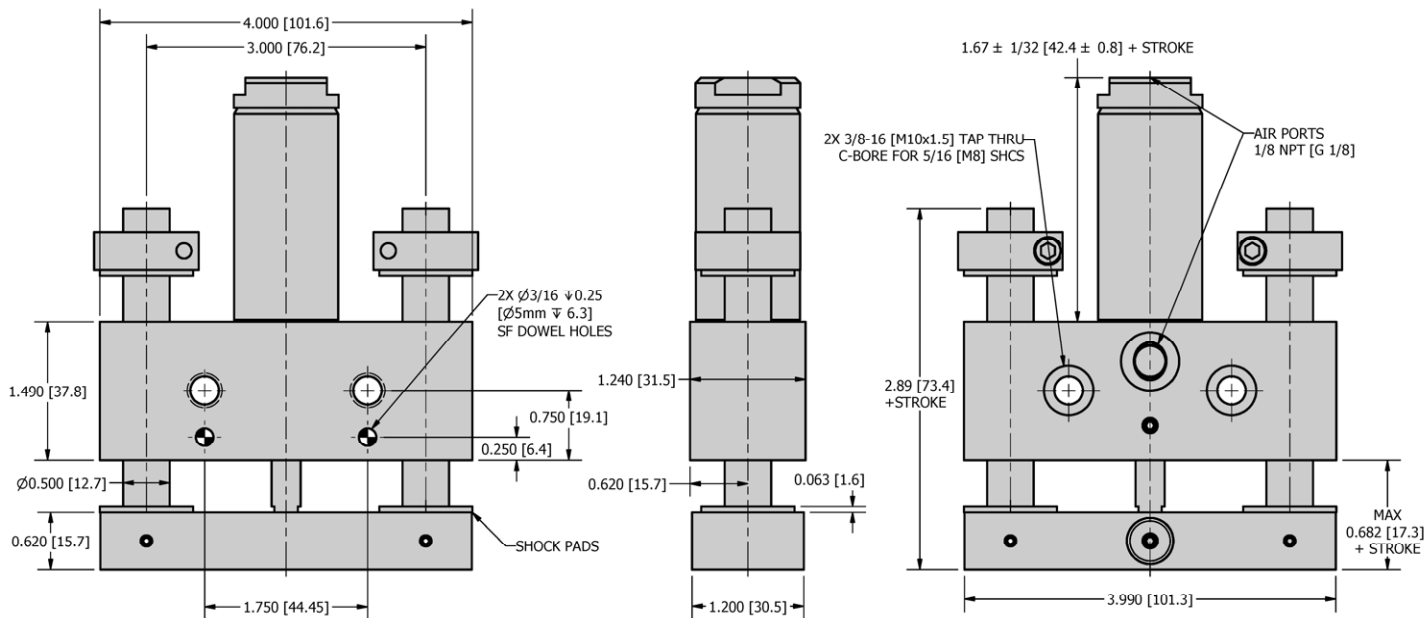

SPECIFICATIONS

| | ET-3 | MET-3 |
|---------------------------------|--------------|------------|
| Maximum Air Pressure | 100 psi | 6.9 bar |
| Thrust Force @ 80 psi / 5.5 bar | 70.4 lbf | 311.9 N |
| Unit Force Factor - Extend | 0.88 lbf/psi | 56.7 N/bar |
| Unit Force Factor - Retract | 0.81 lbf/psi | 52.3 N/bar |
| Base Weight | 1.68 lb | 0.76 kg |
| Additional Weight per Stroke | 0.16 lb/in | 2.9 g/mm |
| Cylinder Bore Diameter | 1.062" | 27 mm |
| Shaft Diameter | 0.500" | 12.7 mm |

LOADING

| | ET-3 | MET-3 |
|---|----------|---------|
| Typical Load (Force + Weight)*Stroke (F+W)*S | 8 lbf-in | 0.9 N-m |
| Max Moment M | 8 lbf-in | 0.9 N-m |
| Typical Dynamic Payload W | 10 lbf | 4.5 kg |

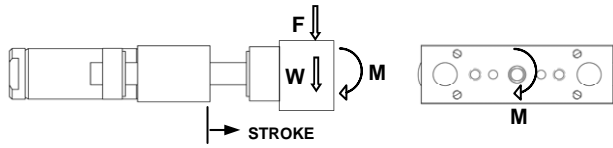
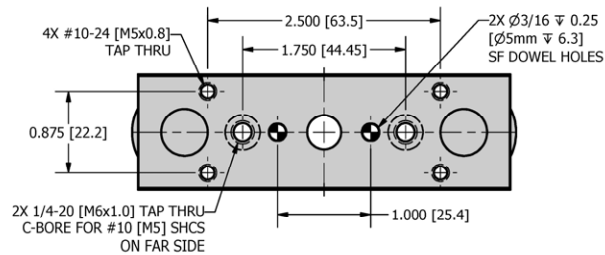

Flow controls recommended for nearly all applications

HOW TO ORDER : BASIC UNIT

ACCESSORIES (order separately)

METRIC BASIC MODEL STROKE SEALS

M **ET-3** - -

METRIC M

STROKE Inch: 1.0" - 10.0" @ 1.0" increments
mm: 25.4 - 254.0 @ 25.4mm increments

SEALS V - Viton (standard Buna - N)

SAMPLE ORDER: ET-3-2.0-V
Ex) ET-3 Thruster with 2 inch stroke and Viton seals

**CUSTOM DESIGNS ALWAYS AVAILABLE
PLEASE CONTACT US FOR INFORMATION**

- MAGNETIC SENSOR KITS * (Cylinder clamp mounted)**
- CSK-N - Magnetic Sensor NPN w/ quick disconnect Kit
 - CSK-P - Magnetic Sensor PNP w/ quick disconnect Kit
 - CSK-R - Magnetic Sensor REED w/ quick disconnect Kit
- * Sensors Kits include (2) sensors and (2) cylinder clamps and (2) 5 meter cables.
- MAGNETIC SENSORS * (Cylinder clamp mounted)**
- CS-N - Magnetic Sensor NPN w/ quick disconnect
 - CS-P - Magnetic Sensor PNP w/ quick disconnect
 - CS-R - Magnetic Sensor REED w/ quick disconnect
- * Includes (1) sensors and (1) cylinder clamp
- SENSOR CABLE**
- SENCAB-5 - Quick Disconnect PUR Cable 5M Length